

DOWNLOAD SERVICE REPAIR MANUAL

**2355, 2555,
2755 and 2855N
Tractors**

**TECHNICAL
MANUAL**

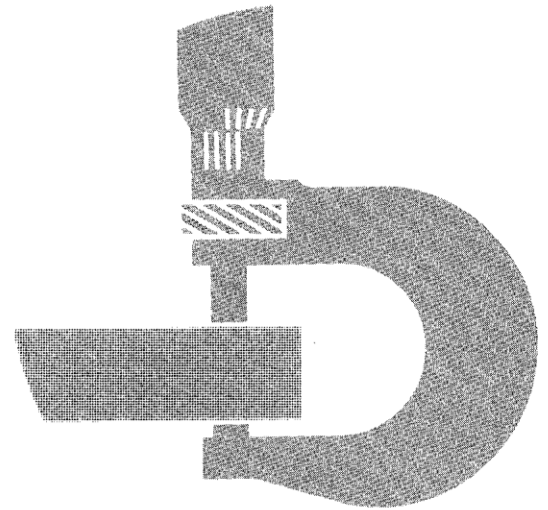

**John Deere Werke Mannheim
TM4434**

Litho in U.S.A. (Nov-89)

2355, 2555, 2755 AND 2855N TRACTORS TECHNICAL MANUAL TM4434 (NOV-89)

SECTION CONTENTS IN GROUPS – REPAIR

05 – SAFETY

10 – GENERAL

- 05 – Specifications
- 10 – Predelivery, delivery and after-sales inspections
- 15 – Lubrication and service
- 20 – Tune-up
- 25 – Tractor separation

20 – ENGINE

- 05 – Radiator, viscous fan drive and fan

30 – FUEL AND AIR INTAKE SYSTEM

- 05 – Fuel tank, auxiliary fuel tank and water trap
- 10 – Cold weather starting aids
- 15 – Speed control linkage
- 20 – Air cleaner

40 – ELECTRICAL SYSTEM

- 05 – Wiring harnesses
- 10 – Controls and instruments (without SOUND-GARD body)
- 15 – Controls and instruments (with SOUND-GARD body)
- 20 – Lighting system
- 25 – Starting motor
- 30 – Alternator

50 – POWER TRAIN

- 05 – Clutch operating systems
- 10 – Engine single-stage clutch (without Reverser)
- 15 – Engine single-stage clutch (with Reverser)
- 20 – Engine dual-stage clutch
- 25 – Hi-Lo shift unit
- 30 – Reverser
- 35 – Creeper transmission
- 40 – Transmission – console shift
- 45 – Transmission – center shift
- 50 – Synchronized transmission and transmission oil pump
- 55 – Collar-shift transmission and transmission oil pumps
- 60 – Differential
- 65 – Final drives
- 70 – Independent PTO shafts
- 75 – Continuous-running PTO's
- 80 – Front PTO
- 85 – Front wheel drive u.j. drive shaft and disk clutch

60 – STEERING SYSTEM AND BRAKES

- 05 – Hydrostatic steering
- 10 – Steering cylinder (without front wheel drive)
- 15 – Power steering
- 20 – Hydraulic brakes
- 25 – Handbrake

COPYRIGHT © 1989 DEERE & Co.
European Office Mannheim
All rights reserved
A John Deere ILLUSTRATION™ Manual
PREVIOUS EDITION
COPYRIGHT © 1987

INHALT-LB701AE-011088

SECTION CONTENTS IN GROUPS – REPAIR

70 – HYDRAULIC SYSTEM

- 05 – Valves
- 10 – Hydraulic pumps
- 15 – Rockshaft
- 25 – Selective control valves (spool type)
- 30 – Selective control valves (poppet valve type)
- 35 – ISO breakaway couplers
- 40 – ISO quick couplers
- 45 – Remote cylinder

80 – MISCELLANEOUS

- 05 – Front axle
- 10 – Front and rear wheels

90 – OPERATOR'S STATION

- 05 – Safe handling of refrigerants
- 06 – Servicing air conditioning system
- 07 – Compressor (up to tractor Serial No. 663 473L)
- 08 – Compressor (from tractor Serial No. 663 474L)
- 09 – Components of air conditioning system
- 10 – Cab ventilation and heating
- 15 – Operator's seats
- 20 – SOUND-GARD Body
- 25 – 2-post roll guard
- 30 – 2-post telescopic roll guard

INHALT-LB702AE-011088

SAFETY AND YOU

This is the safety-alert symbol. When you see this symbol on the machine or in this manual, be alert to the potential for personal injury.



T81389

T81389;053;TMSAFE 19 07OCT85

IMPORTANT

The IMPORTANT message identifies potential problems which may cause consequential damage to machine. Following recommended procedure will instruct technician how to avoid problem.

A68;N01;0000 19 U 05NOV82

NOTES

The word NOTE is followed by a statement that identifies a qualification or exception to a previous statement. A "NOTE" may also identify nice-to-know information pertinent to, but not directly related to previous statement.

A68; N01;0000 19 V 05NOV82



OBSERVE SAFETY RULES

Avoid loose clothing that can catch in moving parts and put you out of work.

Wear your safety glasses while on the job.

Avoid working on equipment with the engine running. If it is necessary to make checks with the engine running, **ALWAYS USE TWO PEOPLE** – with the operator, at the controls, able to see the person doing the checking. Also, put the transmission in neutral, set the brake, and apply safety locks provided. **KEEP HANDS AWAY FROM MOVING PARTS.**

Keep transmission and brake control units properly adjusted at all times. Before making adjustments, stop engine.

Before removing any housing covers, stop engine. Take all objects from your pockets which could fall into the opened housings. Don't let adjusting wrenches fall into opened housings.

Don't attempt to check belt tension while the engine is running.

Don't adjust the fuel system while the machine is in motion.

Before repairing the electrical system, or performing a major overhaul, make sure the batteries are disconnected.

A68; N01;0000 19 S 05NOV82

PREPARE FOR EMERGENCIES

Be prepared if a fire starts.

Keep a first aid kit and fire extinguisher handy.

Keep emergency numbers for doctors, ambulance service, hospital and fire department near your telephone.

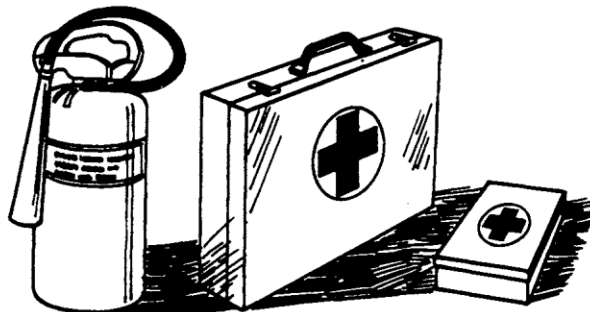

L 114 052

L114052;053;FIR2 19 15MAR89



HANDLE FLUIDS SAFELY – AVOID FIRES

When you work around fuel, do not smoke or work near heaters or other fire hazards.

Store flammable fluids away from fire hazards. Do not incinerate or puncture pressurized containers.

Make sure machine is clean of trash, grease and debris.

Do not store oily rags; they can ignite and burn spontaneously.



TS 227

TS227:053;FLAME 19 05JAN88

PREVENT BATTERY EXPLOSIONS

Keep sparks, lighted matches, and open flame away from the top of battery. Battery gas can explode.

Never check battery charge by placing a metal object across the posts. Use a volt-meter or hydrometer.

Do not charge a frozen battery; it may explode. Warm battery to 16°C (60°F).

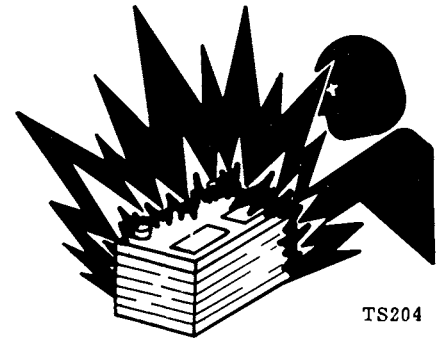

TS204

TS204:053;SPARKS 19 28JUN88

PREVENT ACID BURNS

Sulfuric acid in battery electrolyte is poisonous. It is strong enough to burn skin, eat holes in clothing and cause blindness if splashed into eyes.

Avoid the hazard by:

1. Filling the batteries in a well-ventilated area.
2. Wearing eye protection and rubber gloves.
3. Avoiding breathing fumes when electrolyte is added.
4. Avoiding spilling or dripping electrolyte.
5. Use proper jump start procedure.

If you spill acid on yourself:

1. Flush your skin with water.
 2. Apply baking soda or lime to help neutralize the acid.
 3. Flush your eyes with water for 10 – 15 minutes.
- Get medical attention immediately.

If acid is swallowed:

1. Drink large amounts of water or milk.
2. Then drink milk of magnesia, beaten eggs or vegetable oil.
3. Get medical attention immediately.

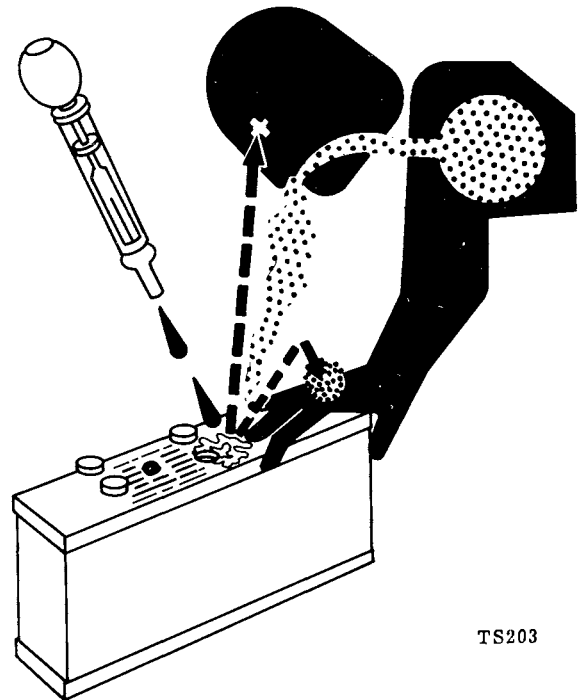

TS203

TS203:053;POISON 19 21DEC87



AVOID HIGH-PRESSURE FLUIDS

Escaping fluid (fuel or hydraulic oil) under pressure can penetrate the skin causing serious injury. Relieve pressure before disconnecting hydraulic or other lines. Tighten all connections before applying pressure. Keep hands and body away from pinholes and nozzles which eject fluids under high pressure. Use a piece of cardboard to search for leaks.

If ANY fluid is injected into the skin, it must be surgically removed within a few hours by a doctor familiar with this type of injury, or gangrene may result.

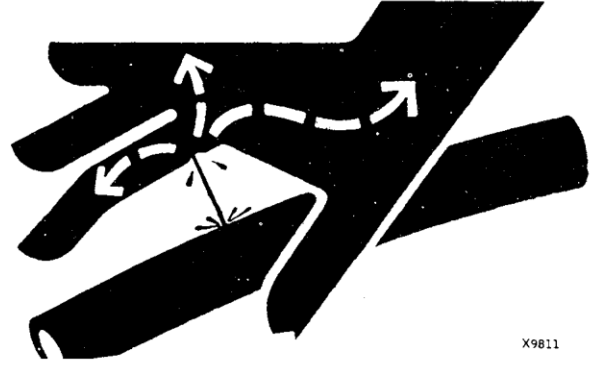

X9811

X9811;053;FLUID 19 18SEP87

AVOID HARMFUL ASBESTOS DUST

Avoid breathing dust that may be generated when handling components containing asbestos fibers. Inhaled asbestos fibers may cause lung cancer.

Components in John Deere products that may contain asbestos fibers are brake pads, brake band and lining assemblies, clutch plates and some gaskets. The asbestos used in these components is usually found in a resin or sealed in some way. Normal handling is not hazardous as long as airborne dust containing asbestos is not generated.

Avoid creating dust. Never use compressed air for cleaning. Avoid brushing or grinding of asbestos-containing materials. When servicing, wear an approved respirator. A special vacuum cleaner is recommended to clean asbestos. If not available, wet the asbestos-containing materials with a mist of oil or water.

Keep bystanders away from the area.

Please note designations on spare parts.

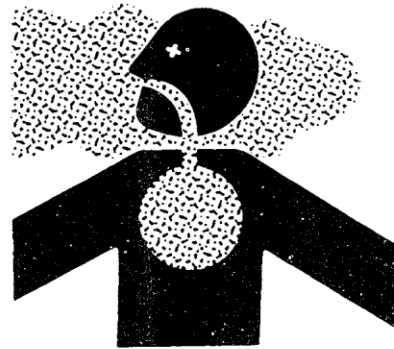

TS 220



L 114 051

TS220.L114051;053;DUST 19 14APR88



WORK IN VENTILATED AREA

Engine exhaust fumes can cause sickness or death. If it is necessary to run an engine in an enclosed area, remove the exhaust fumes from the area with an exhaust pipe extension.

If you do not have an exhaust pipe extension, open the doors and get outside air into the area.

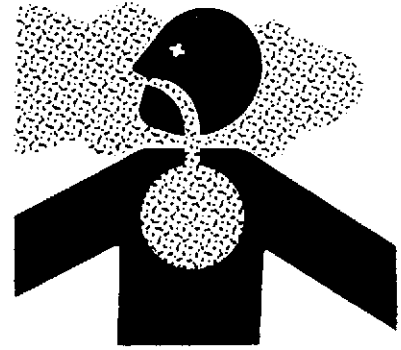

TS 220

TS220;053;A/R 19 05JAN88

WORK IN CLEAN AREA

Before starting a job:

- Clean work area and machine.
- Make sure you have all necessary tools to do your job.
- Have the right parts on hand.
- Read all instructions thoroughly; do not attempt shortcuts.

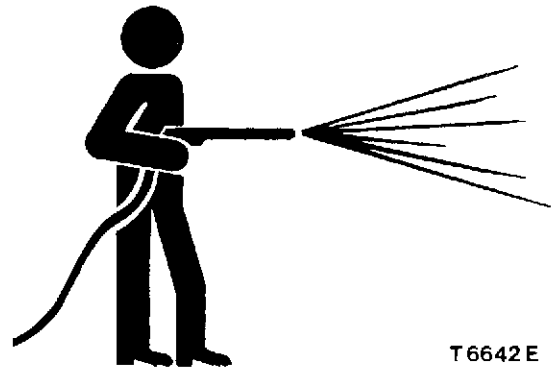

T 6642 E

T6642E;053;CLEAN 19 19JAN88

PARK MACHINE SAFELY

Before working on the machine:

- Lower all equipment to the ground.
- Stop the engine and remove the key.
- Disconnect the battery ground strap.
- Hang a "DO NOT OPERATE" tag in operator station.

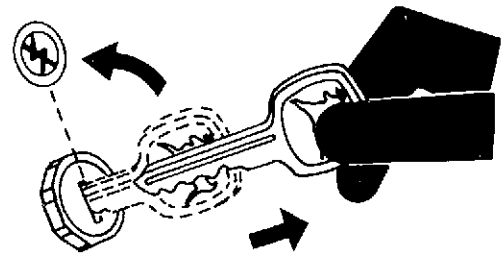

TS 230

TS230;053;PARK 19 05JAN88

PREVENT MACHINE RUNAWAY

Avoid possible injury or death from a machine runaway.

Do not start the engine by shorting across starter terminals. Machine will start in gear if normal circuitry is bypassed.

NEVER start engine while standing on ground. Start engine only from operator's seat, with the transmission in neutral or "Park".



TS177

TS177;053;BYPAS1 19 21MAY85



SERVICE FRONT-WHEEL DRIVE TRACTOR SAFELY

When servicing front-wheel drive tractor with the rear wheels supported off the ground and rotating wheels by engine power, always support front wheels in a similar manner. Loss of electrical power or transmission/hydraulic system pressure will engage the front driving wheels, pulling the rear wheels off the support if front wheels are not raised. Under these conditions, front drive wheels can engage even with switch in disengaged position.

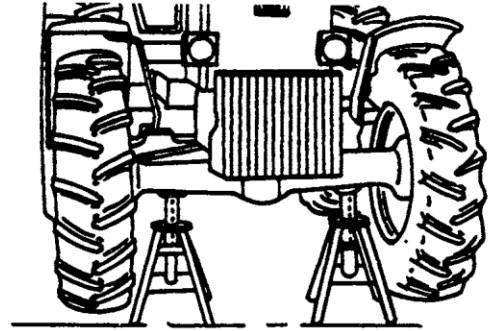

L114050

L114050-ESPDAE-140388

SERVICE MACHINE SAFELY

Tie long hair behind your head. Do not wear a necktie, scarf, loose clothing or necklace when you work near machine tools or moving parts. If these items were to get caught, severe injury could result.

Remove rings and other jewelry to prevent electrical shorts and entanglement in moving parts.

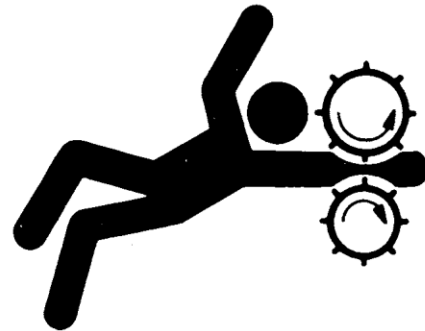

TS228

TS228;053;LOOSE 19 21DEC87

UNDERSTAND CORRECT SERVICE

Illuminate your work area adequately but safely. Use a portable safety light for working inside or under the machine. Make sure the bulb is enclosed by a wire cage. The hot filament of an accidentally broken bulb can ignite spilled fuel or oil.

Catch draining fuel, oil, or other fluids into suitable containers. Do not use food or beverage containers that may mislead someone into drinking from them. Wipe up spills at once.



TS 223

TS223;053;LIGHT 19 23FEB88

USE TOOLS PROPERLY

Use tools appropriate to the work. Makeshift tools, parts, and procedures will not make good repairs.

Use pneumatic and electric tools only to loosen threaded parts and fasteners. Never use such tools to tighten fasteners, especially on light alloy parts.

Use only replacement parts meeting John Deere specifications.

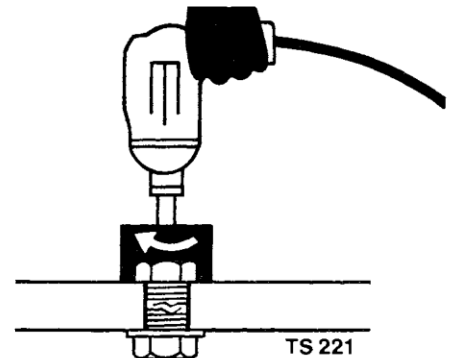

TS 221

TS221;053;REPAIR 19 21DEC87



SUPPORT MACHINE PROPERLY

Always lower the attachment or implement to the ground before you work on the machine. If you must work on a lifted machine or attachment, securely support the machine or attachment.

Do not support the machine on cinder blocks, hollow tiles or props that may crumble under continuous load. Do not work under a machine that is supported solely by a jack. Follow recommended procedures in this manual.

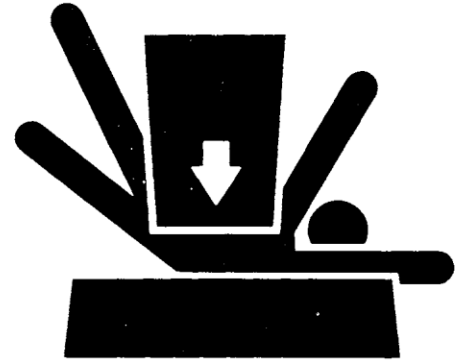

TS 229

TS229;053;LOWER 19 21DEC87

USE PROPER LIFTING EQUIPMENT

Lifting heavy components incorrectly can cause severe injury or machine damage.

Follow recommended procedure for removal and installation of components in the manual.

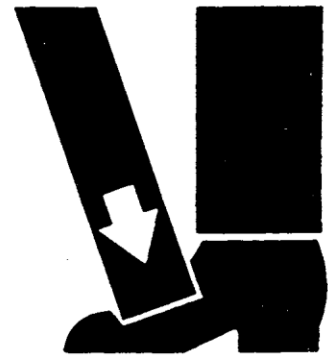

TS 226

TS226;053;LIFT 19 05JAN88

SERVICE TIRES SAFELY

Explosive separation of a tire and rim parts can cause serious injury or death.

Only attempt to mount a tire if you have the proper equipment and experience to perform the job.

Always maintain the correct tire pressure. Do not inflate tires above the recommended pressure.

When inflating tires, use a clip-on chuck and extension hose long enough to allow you to stand to one side and NOT in front of or over the tire assembly. Use a safety cage if available.

Check wheels for low pressure, cuts, bubbles, damaged rims or missing lug bolts and nuts.

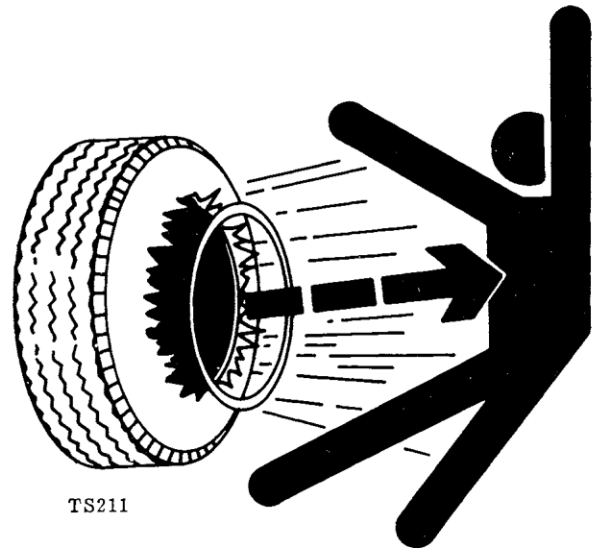

TS211

TS211;053;RIM 19 21DEC87



KEEP CAB/ROPS INSTALLED PROPERLY

Make certain all parts are reinstalled correctly if the cab or roll-over protective structure (ROPS) is loosened or removed for any reason. Tighten mounting bolts to specified torque.

Protection offered by cab or ROPS is impaired if subjected to structural damage, is involved in an overturn incident or is altered in any way by welding, bending, drilling or cutting. A damaged cab or ROPS should be replaced, not reused.

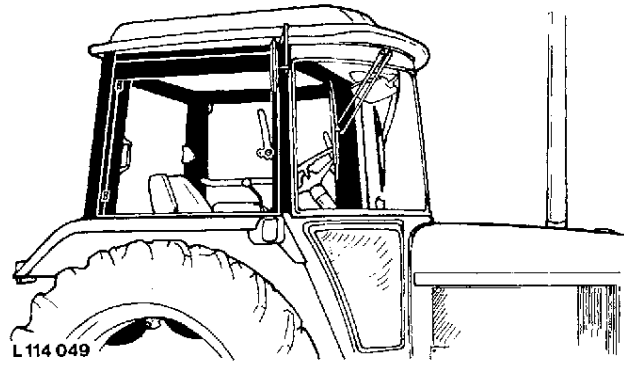

L114049;053;ROPS 19 15MAR89

REPLACE SAFETY SIGNS

Replace missing or damaged safety signs. See the machine operator's manual for correct safety sign placement.

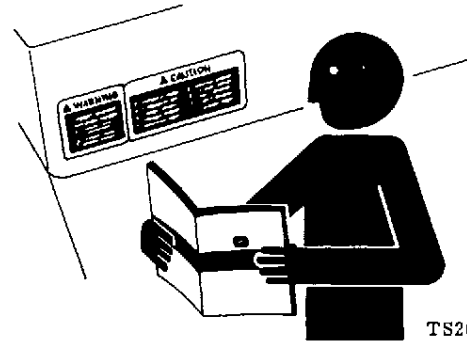

TS201;053;SIGNS1 19 22DEC87

OBSERVE ENVIRONMENTAL PROTECTION REGULATIONS

Be mindful of the environment and ecology.

Before draining any fluids, find out the correct way of disposing of them.

Observe the relevant environmental protection regulations when disposing of oil, fuel, coolant, brake fluid, filters and batteries.

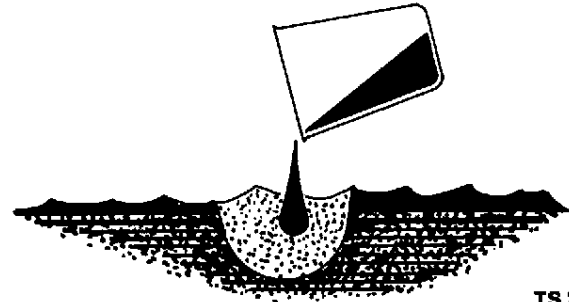

TS222-ESPDAE-140388

LIVE WITH SAFETY

Before returning machine to customer, make sure machine is functioning properly, especially the safety systems. Install all guards and shields.



TS231

TS231;053;LIVE 19 05JAN88

Section 10 GENERAL

05 – SPECIFICATIONS

	2355	2555	2755	2855N
Specifications	X	X	X	X
– Serial number plates	X	X	X	X
– Product identification number	X	X	X	X
– Engine serial number	X	X	X	X
– Transmission serial number	X	X	X	X
– Front wheel drive axle serial number	X	X	X	X
– SOUND-GARD Body serial number	X	X	X	X
– Model serial numbers	X	X	X	X
– Engine	X	X	X	X
– Engine clutch	X	X	X	X
– Cooling system	X	X	X	X
– Fuel system	X	X	X	X
– Electrical system	X	X	X	X
– Synchronized transmission	X	X	X	X
– Collar shift transmission	X	X	X	X
– Hi-Lo shift unit	X	X	X	X
– Reverser transmission	X	X	X	X
– Creeper transmission	X	X	X	X
– Differential and final drives	X	X	X	X
– Differential lock	X	X	X	X
– PTO	X	X	X	X
– Continuous-running PTO	X	X	X	X
– PTO speeds	X	X	X	X
– Front PTO	X	X	X	X
– Front wheel drive	X	X	X	X
– Hydrostatic steering	X	X	X	X
– Power steering	X	X	X	X
– Foot brakes	X	X	X	X
– Handbrake	X	X	X	X
– Hydraulic system	X	X	X	X
– Rockshaft	X	X	X	X
– Ground travel speeds	X	X	X	X
– Front and rear wheels	X	X	X	X
– Dimensions and weights	X	X	X	X
– Capacities	X	X	X	X
– Standard torques for hardware	X	X	X	X

ALLGEM-LB71001AE-011088

**10 – PREDELIVERY, DELIVERY AND
AFTER-SALES INSPECTIONS**

Special tools	10-1
Specifications	10-2
Capacities	10-3
Torques for hardware	10-3
Predelivery inspection	10-5
Delivery inspection	10-28
After-sales inspection	10-29

15 – LUBRICATION AND SERVICE

Capacities and service intervals	15-1
Lubricants and service intervals	15-2
General	15-3
Diesel engine oil	15-3
Transmission/hydraulic oil	15-4
Oil for front wheel drive axle	15-4
EP multi-purpose grease	15-5
Storing lubricants	15-5
Brake fluid for hydraulically operated clutch	15-5
Engine coolant	15-6
Checking engine oil level	15-6
Changing engine oil	15-7
Changing engine oil filter	15-7
Checking fuel filter	15-8
Replacing fuel filter	15-8
Replacing coolant	15-9
Checking transmission/hydraulic system oil level	15-10
Changing transmission/hydraulic oil	15-11
Replacing transmission/hydraulic oil filter element	15-12
Replacing hydraulic oil return flow filter	15-12
Replacing hydrostatic steering filter (without SOUND-GARD Body)	15-13

	2355	2555	2755	2855N
Special tools	X	X	X	X
Specifications	X	X	X	X
Capacities	X	X	X	X
Torques for hardware	X	X	X	X
Predelivery inspection	X	X	X	X
Delivery inspection	X	X	X	X
After-sales inspection	X	X	X	X
Capacities and service intervals	X	X	X	X
Lubricants and service intervals	X	X	X	X
General	X	X	X	X
Diesel engine oil	X	X	X	X
Transmission/hydraulic oil	X	X	X	X
Oil for front wheel drive axle	X	X	X	X
EP multi-purpose grease	X	X	X	X
Storing lubricants	X	X	X	X
Brake fluid for hydraulically operated clutch	X	X	X	
Engine coolant	X	X	X	X
Checking engine oil level	X	X	X	X
Changing engine oil	X	X	X	X
Changing engine oil filter	X	X	X	X
Checking fuel filter	X	X	X	X
Replacing fuel filter	X	X	X	X
Replacing coolant	X	X	X	X
Checking transmission/hydraulic system oil level	X	X	X	X
Changing transmission/hydraulic oil	X	X	X	X
Replacing transmission/hydraulic oil filter element	X	X	X	X
Replacing hydraulic oil return flow filter	X	X	X	X
Replacing hydrostatic steering filter (without SOUND-GARD Body)	X	X	X	X

15 – LUBRICATION AND SERVICE (Contd.)

	2355	2555	2755	2855N
Cleaning hydraulic pump filter strainer 15-13	X	X	X	X
Replacing brake fluid (hydraulically operated clutch) 15-13	X	X	X	
Checking axle housing oil level 15-14	X	X	X	X
Checking oil level in wheel hub housings 15-14	X	X	X	X
Changing front axle oil 15-14	X	X	X	X
Cleaning lubricating points 15-15	X	X	X	X
Lubricating clutch throw-out bearing (with mechanically operated clutch) 15-15	X	X	X	X
Lubricating front axle and front wheels 15-15	X	X	X	X
Lubricating u.j. drive shaft (with front wheel drive) 15-16	X	X	X	X
Lubricating rear axle bearings 15-17	X	X	X	X
Lubricating front PTO 15-17	X	X	X	X
Lubricating three-point hitch 15-17	X	X	X	X

20 - TUNE-UP

	2355	2555	2755	2855N
Specifications	X	X	X	X
Preliminary engine testing	X	X	X	X
Checking air cleaner element	X	X	X	X
Checking air intake system connections for leaks	X	X	X	X
Checking crankcase vent tube for clogging	X	X	X	X
Cleaning radiator side panels and grille screens	X	X	X	X
Cleaning radiator and oil cooler	X	X	X	X
Cleaning condenser	X	X	X	X
Checking radiator cap	X	X	X	X
Checking radiator for leaks	X	X	X	X
Checking thermostat	X	X	X	X
Checking fuel transfer pump	X	X	X	X
Checking fuel filter	X	X	X	X
Checking fuel tank	X	X	X	X
Checking auxiliary fuel tank	X	X	X	X
Cleaning water trap	X	X	X	X
Checking fuel injection pump adjustment	X	X	X	X
Checking engine slow and fast idle speeds	X	X	X	X
Checking speed control linkage adjustment	X	X	X	X
Checking batteries	X	X	X	X
Checking fan belt tension	X	X	X	X
Checking compressor belt tension	X	X	X	X
Checking operation of neutral start system	X	X	X	X
Checking operation of starting motor	X	X	X	X
Checking lighting system	X	X	X	X
Final engine check	X	X	X	X
Checking tractor operation	X	X	X	X

25 – TRACTOR SEPARATION

	2355	2555	2755	2855N
Special tools	X	X	X	X
Specifications	X	X	X	X
Torques for hardware	X	X	X	X
Capacities	X	X	X	X
Standard torques for hardware	X	X	X	X
Important notes	X	X	X	X
Removing tractor front end	X	X	X	X
Installing tractor front end	X	X	X	X
Separating between engine and clutch housing	X	X	X	X
Joining tractor between engine and clutch housing	X	X	X	X
Removing engine	X	X	X	X
Installing engine	X	X	X	X
Removing clutch housing	X	X	X	X
Installing clutch housing	X	X	X	X
Removing transmission	X	X	X	X
Installing transmission	X	X	X	X
Removing final drives	X	X	X	X
Installing final drives	X	X	X	X
Removing rockshaft	X	X	X	X
Installing rockshaft	X	X	X	X
Removing front axle	X	X	X	X
Installing front axle	X	X	X	X
Removing front wheel drive axle	X	X	X	X
Installing front wheel drive axle	X	X	X	X
Removing SOUND-GARD Body	X	X	X	
Installing SOUND-GARD Body	X	X	X	
Removing front PTO	X	X	X	X
Installing front PTO	X	X	X	X

DOWNLOAD SERVICE REPAIR MANUAL