

JOHN DEERE 850 900HC 950 1050 TRACTOR Service Repair Manual



850, 900HC, 950 and 1050 Tractors



JOHN DEERE

TECHNICAL MANUAL

850, 900HC, 950 and 1050
Tractors

TM1192 (01AUG86) English

John Deere
Lawn & Grounds Care Division
TM1192 (01AUG86)

LITHO IN U.S.A.
ENGLISH



GET MORE:

**Hydraulic
System, Setting
Instructions, Functional
Description, Electrical
System And more**

**[Click Here BUY NOW](#)
[Then Instant](#)
[Download the](#)
[Complete Manual.](#)**

850, 900HC, 950 AND 1050 TRACTORS

Technical Manual

TM-1192 (Aug-86)

SECTION AND GROUP CONTENTS

SECTION 10 - GENERAL

- Group 00 - Specifications and Special Tools
- Group 05 - Predelivery, Delivery, and After-Sale Services—850 and 950 Tractors
- Group 06 - Predelivery, Delivery, and After-Sale Services—1050 Tractor
- Group 10 - Tune-Up
- Group 15 - Lubrication
- Group 20 - Separation

SECTION 20 - ENGINE REPAIR

- Group 00 - Specifications and Special Tools
- Group 05 - Cylinder Head, Valves, and Camshaft—850 and 950 Tractors
- Group 06 - Cylinder Head, Valves, and Camshaft—1050 Tractor
- Group 10 - Cylinder Block, Liners, Pistons and Rods
- Group 15 - Crankshaft, Main Bearings, and Flywheel
- Group 20 - Lubrication System
- Group 25 - Cooling System—850 and 950 Tractors*
- Group 26 - Cooling System—850, 950, and 1050 Tractors**

SECTION 30 - FUEL AND AIR REPAIR

- Group 00 - Specifications and Special Tools
- Group 05 - 850 and 950 Air Intake System
- Group 06 - 1050 Air Intake System
- Group 10 - Diesel Fuel System
- Group 15 - 850 and 950 Control Linkage*
- Group 16 - 850, 950, and 1050 Control Linkage**

SECTION 40 - ELECTRICAL REPAIR

- Group 00 - Specifications and Special Tools
- Group 05 - General Information
- Group 10 - Charging System
- Group 15 - Starting Circuit
- Group 20 - Lighting and Accessory Circuits

SECTION 50 - POWER TRAIN REPAIR

- Group 00 - Specifications and Special Tools
- Group 05 - Engine and Clutch Linkage—850 (-16000) and 950 (-20000) Tractors

*850 (-009000), 950 (-012000)

**850 (009001-), 950 (012001-)

SECTION 50—POWER TRAIN REPAIR—Continued

- Group 06 - Engine and Clutch Linkage 850 (16001-), 950 (20001-) and 1050 Tractor
- Group 10 - Sliding Gear Transmission 850 (-16000) and 950 (-20000) Tractors
- Group 11 - Sliding Gear Transmission 850 (16001-), 950 (20001-) and 1050 Tractor
- Group 15 - PTO 850 (-16000) and 950 (-20000) Tractors
- Group 16 - PTO 850 (16001), 950 (20001-) and 1050 Tractor
- Group 20 - Differential 850 (-16000) and 950 (-20000) Tractors
- Group 21 - Differential 850 (16001-), 950 (20001-) and 1050 Tractor
- Group 25 - Final Drive—850-950 Tractors
- Group 26 - Final Drive—1050 Tractor
- Group 27 - Drop Housings and Final Drives—900HC Tractor
- Group 30 - Mechanical Front-Wheel Drive

SECTION 60 - STEERING/BRAKES REPAIR

- Group 00 - Specifications and Special Tools
- Group 05 - Steering
- Group 10 - Power Steering
- Group 15 - Brakes

SECTION 70 - HYDRAULIC REPAIR

- Group 00 - Specifications and Special Tools
- Group 05 - Hydraulic Pump and Oil Filters
- Group 10 - 850/950 Rockshaft and Implement Hitches
- Group 15 - 1050 Rockshaft and Implement Hitches
- Group 20 - Selective Control Valve

SECTION 80 - MISCELLANEOUS REPAIR

- Group 00 - Specifications and Special Tools
- Group 05 - Front Axle Assembly
- Group 10 - Wheels

COPYRIGHT © 1986 DEERE & COMPANY

Moline, Illinois
All rights reserved
Previous Edition
Copyright © 1984
Copyright © 1980
Copyright © 1979
Copyright © 1978
Copyright © 1977
DEERE & COMPANY

SECTION AND GROUP CONTENTS—Continued

- SECTION 90 - OPERATOR STATION REPAIR**
 Group 00 - Specifications and Special Tools
 Group 05 - ROLL-GARD®
 Group 10 - Canopy
- SECTION 220 - ENGINE OPERATION AND TESTS**
 Group 00 - Specifications and Special Tools
 Group 05 - System Operation
 Group 10 - System Tests and Diagnosis
- SECTION 230 - FUEL/AIR OPERATION AND TESTS**
 Group 00 - Specifications and Special Tools
 Group 05 - 850 and 950 Air Intake System
 Group 06 - 1050 Air Intake System
 Group 10 - Diesel Fuel System
 Group 15 - Speed Control Linkage—850 and 950 Tractors*
 Group 16 - Speed Control Linkage—850, 950, and 1050 Tractors**
- SECTION 240 - ELECTRICAL OPERATION AND TESTS**
 Group 00 - Specifications and Special Tools
 Group 05 - General Information and Diagrams
 Group 10 - Charging System Diagnosis
 Group 15 - Starting Circuit Diagnosis
 Group 20 - Lighting and Accessory Circuits
- SECTION 250 - POWER TRAIN OPERATION AND TESTS**
 Group 00 - Specifications and Special Tools
 Group 05 - Clutch and Transmission Operation—850 (-16000) and 950 (-20000) Tractors
 Group 06 - Clutch and Transmission Operation—850 (16001-), 950 (20001-) and 1050 Tractor
 Group 10 - Trouble Shooting the Clutch, Transmission and PTO—850 (-16000) and 950 (-20000) Tractors
 Group 11 - Trouble Shooting the Clutch, Transmission and PTO—850 (16001-), 950 (20001-) and 1050 Tractor
 Group 15 - Differential and Final Drive—850 (-16000) and 950 (-20000) Tractors
 Group 16 - Differential and Final Drive—850 (16001-), 950 (20001-) and 1050 Tractor
 Group 20 - Mechanical Front-Wheel Drive
- *850 (-009000), 950 (-012000)
 **850 (009001-), 950 (012001-)

- SECTION 260 - STEERING/BRAKES OPERATION AND TESTS**
 Group 00 - Specifications and Special Tools
 Group 05 - Steering
 Group 10 - Power Steering
 Group 15 - Brakes
- SECTION 270 - HYDRAULIC OPERATION AND TESTS**
 Group 00 - Specifications and Special Tools
 Group 05 - Hydraulic System Operation
 Group 10 - Hydraulic System Tests and Diagnosis
 Group 15 - Hydraulic Pump
 Group 20 - 850/950 Rockshaft and Implement Hitches
 Group 25 - 1050 Rockshaft and Implement Hitches
 Group 30 - Selective Control Valve

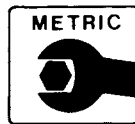

This tractor is of metric design. All hardware is therefore metric. Make sure you use the specified metric hardware when replacement becomes necessary. For your convenience most specifications are given in customary U.S. measurement with metric measurement following. Some specifications cannot be converted. Those appear in metric only.

All information, illustrations and specifications contained in this technical manual are based on the latest information available at the time of publication. The right is reserved to make changes at any time without notice.

Section 10 GENERAL

CONTENTS OF THIS SECTION

	Page		Page
GROUP 00 - SPECIFICATIONS		Group 10 - TUNE-UP	
General Tractor Specifications		Preliminary Engine Testing	10-1
850 and 950 Tractors	00-1	Tune-Up	10-1
1050 Tractors	00-3	Operation	10-5
Predelivery	00-4	General	10-5
Tune-Up	00-6	GROUP 15 - LUBRICATION	
Lubrication	00-6	Lubricants	15-1
Separation	00-7	Engine	15-2
Special Tools	00-8	Transmission-Hydraulic System	15-3
GROUP 05 - PREDELIVERY, DELIVERY, AND AFTER-SALE SERVICES 850 AND 950 TRACTORS		Front Wheel Bearings	15-5
Before Starting Tractor	05-1	Grease Fittings	15-7
Predelivery Services	05-4	GROUP 20 - SEPARATION	
Delivery Services	05-13	Removing Front End (850-950)	20-1
After-Sale Services	05-14	(1050)	20-6
GROUP 06 - PREDELIVERY, DELIVERY, AND AFTER-SALE SERVICES 1050 TRACTOR		Separating Front End from Clutch Housing (850-950)	20-2
Before Starting Tractor	06-1	(1050)	20-8
Predelivery Services	06-5	Engine Removal (850-950)	20-4
Delivery Services	06-11	(1050)	20-10
After-Sale Services	06-12	Separating Clutch Housing from Transmission	20-12
		Removing Rear Axle Housing	20-14

Group 00

SPECIFICATIONS AND SPECIAL TOOLS GENERAL TRACTOR SPECIFICATIONS (850-950)

	850 TRACTOR	950 TRACTOR
HORSEPOWER (Official PTO horsepower)	16.61 kW (22.27 hp) at 2600 rpm	20.40 kW (27.36 hp) at 2400 rpm
ENGINE:		
Type	3-cylinder, in-line, valve-in-head, diesel	3-cylinder, in-line, in-line, valve-in-head, diesel
Slow idle speed	800 rpm	800 rpm
Working speed range	1900 to 2600 rpm	1700 to 2400 rpm
Bore and stroke	80 x 85 mm (3.15 x 3.35 in.)	90 x 90 mm (3.54 x 3.54 in.)
Displacement	1.3 L (78 cu-in)	1.7 L (105 cu-in)
Compression ratio	21 to 1	20 to 1
Firing order (No. 1 in rear)	1-3-2	1-3-2
Valve clearance		
Intake	0.20 mm (0.008 in.)	0.15 mm (0.006 in.)
Exhaust	0.20 mm (0.008 in.)	0.15 mm (0.006 in.)

SPECIFICATIONS (850 and 950)—Continued

	850	950
Injection pump timing	26° BTDC	25° BTDC
Lubrication system	force-feed, pressurized with full-flow filter	force-feed, pressurized with full-flow filter
FUEL SYSTEM:		
Type	precombustion chamber	precombustion chamber
Injection pump type	plunger	plunger
Air cleaner	dry type	dry type
COOLING SYSTEM:		
Type	pressurized with centrifugal pump	pressurized with centrifugal pump
Temperature control	heavy duty thermostat	heavy duty thermostat
CAPACITIES		
Fuel tank	32 L (8.5 U.S. gal.)	32 L (8.5 U.S. gal.)
Cooling system	5.5 L (6 U.S. qt.)	6 L (6.5 U.S. qt.)
Crankcase (with filter change)	4.5 L (5 U.S. qt.)	6.4 L (7 U.S. qt.)
Transmission-hydraulic system		
850 (-16000) and 950 (-20000)	18 L (19 U.S. qt.)	18 L (19 U.S. qt.)
850 (16001-) , 950 (20001-)		
2WD	20 L (21 U.S. qt.)	20 L (21 U.S. qt.)
850 (16001-) , 950 (20001-)		
MFWD	22 L (23 U.S. qt.)	22 L (23 U.S. qt.)
MFWD Axle	6.5 L (6.9 U.S. qt.)	8.5 L (9 U.S. qt.)
TRANSMISSION:		
Type	2-speed range selector and 4-speed gear selector	2-speed range selector and 4-speed gear selector
Gear selections	8 forward and 2 reverse	8 forward and 2 reverse
Clutch		
850 (-16000) and 950 (-20000)	single-disk, dry	single-disk, dry
850 (16001-) and 950 (20001-)	two-stage transmission clutch	two-stage transmission clutch
POWER TAKE-OFF:		
Type		
850 (-16000) and 950 (-20000)	transmission driven, with overrunning clutch	transmission driven, with overrunning clutch
850 (16001-) and 950 (20001-)	continuous running clutch	continuous running clutch
Speed (2260 engine rpm)	540 rpm	540 rpm
Size	35 mm (1-3/8 in.)	35 mm (1-3/8 in.)
Clutch		
850 (-16000) and 950 (-20000)	uses transmission clutch	uses transmission clutch
850 (16001-) and 950 (20001-)	two-stage transmission clutch	two-stage transmission clutch
HYDRAULIC SYSTEM:		
Type	open center, constant flow	open center, constant flow
Working pressure	13 790 kPa (138 bar) (2000 psi)	13 790 kPa (138 bar) (2000 psi)
Pump	gear pump, driven by engine	gear pump, driven by engine
BRAKES		
Type	mechanical dry, internal expanding shoe	mechanical, dry, internal expanding shoe
ELECTRICAL SYSTEM:		
Type	12-volt, negative ground	12-volt, negative ground
Battery	one, 12-volt, BCI group 30H, 475 amps cold cranking, 160 minutes reserve capacity	one, 12-volt, BCI group 30H, 475 amps cold cranking, 160 minutes reserve capacity
Alternator	25-amp	25-amp
TIRES AND TREADS:		
	See pages 05-6 and 05-7 in this section.	See pages 05-6 and 05-7 in this section.

	850	950
DIMENSIONS:		
Wheelbase	850 (-16000) 1.63 m (64 in.)	1.75 m (69 in.)
	850 (16001-) 1.7 m (67.5 in.)	
Overall length	850 (-16000) 2.29 m (118 in.)	3.10 m (122 in.)
	850 (16001-) 3.07 m (121 in.)	
Height to muffler cover*	2.18 m (85.8 in.)	2.28 m (89.6 in.)
Height to top of ROLL-GARD® Canopy*	2.06 m (81.1 in.)	2.13 m (84.0 in.)
Overall width (minimum tread)	1.35 m (53 in.)	2.48 m (58 in.)
Turning radius	2.80 m (110 in.)	2.99 m (118 in.)
SHIPPING WEIGHT**	1065 kg (2350 lbs.)	1200 kg (2650 lbs.)

*850 Tractor equipped with 11.2-24 rear tires and 5.00-15 front tires. 950 Tractor equipped with 12.4-28 rear tires and 5.50-16 front tires.

**Equipped for average field service, without fuel and ballast.

TRAVEL SPEEDS:*		850 Tractor	950 Tractor
Gear	Rated Engine Speed (2600 rpm)	Standard PTO Speed (2260 rpm)	Rated Engine Speed (2400 rpm)
			Standard PTO Speed (2260 rpm)
1	1.3 km/h 0.8 mph	1.1 km/h 0.7 mph	1.3 km/h 0.8 mph
2	1.8 km/h 1.1 mph	1.6 km/h 1.0 mph	1.9 km/h 1.2 mph
3	2.7 km/h 1.7 mph	2.4 km/h 1.5 mph	2.8 km/h 1.7 mph
4	4.0 km/h 2.5 mph	3.5 km/h 2.2 mph	4.1 km/h 2.6 mph
5	6.0 km/h 3.8 mph	5.2 km/h 3.3 mph	6.2 km/h 3.9 mph
6	8.6 km/h 5.4 mph	7.5 km/h 4.7 mph	8.9 km/h 5.5 mph
7	12.7 km/h 8.0 mph	11.1 km/h 6.9 mph	13.1 km/h 8.2 mph
8	18.7 km/h 11.7 mph	16.3 km/h 10.2 mph	19.3 km/h 12.1 mph
1R	1.8 km/h 1.1 mph	1.6 km/h 1.0 mph	1.9 km/h 1.2 mph
2R	8.6 km/h 5.4 mph	7.5 km/h 4.7 mph	8.9 km/h 5.5 mph

*850 Tractor equipped with 11.2-24 rear tires. 950 Tractor equipped with 12.4-28 rear tires.

GENERAL TRACTOR SPECIFICATIONS (1050)

HORSEPOWER (Factory observed PTO horsepower)

24.6 kW (33 hp) at 2400 rpm

ENGINE:

Type	3-cylinder, in-line, valve-in-head, turbocharged diesel
Slow idle speed	800 rpm
Working speed range	1700 to 2400 rpm
Bore and stroke	90 x 90 mm (3.54 x 3.54 in.)
Displacement	1717 cm ³ (105 cu-in)
Compression ratio	21 to 1
Firing order (No. 1 in rear)	1-3-2
Valve clearance	
Intake	0.15 mm (0.006 in.)
Exhaust	0.15 mm (0.006 in.)
Injection pump timing	25° BTDC
Lubrication system	force-feed, pressurized with full-flow filter

SPECIFICATIONS (1050)—Continued

FUEL SYSTEM:

Type	precombustion chamber
Injection pump type	plunger
Air cleaner	dry type with secondary element

COOLING SYSTEM:

Type	pressurized with centrifugal pump
Temperature control	heavy duty thermostat

CAPACITIES:

Fuel tank	42 L (11 U.S. gallons)
Cooling system	6.7 L (7.5 U.S. quarts)
Crankcase (with filter change)	6.4 L (7 U.S. quarts)
Transmission-hydraulic system	26 L (7 U.S. gallons)
Front axle housing	8.5 L (9 U.S. quarts)

TRANSMISSION:

Type	2-speed range selector and 4-speed gear selector
Gear selections	8 forward and 2 reverse
Clutch	two-stage, dry

POWER TAKE-OFF:

Type	continuous running
Speed (2260 engine rpm)	540 rpm
Size	35 mm (1-3/8 in.)
Clutch	uses two-stage transmission clutch

HYDRAULIC SYSTEM:

Type	open center, constant flow
Working pressure	13800 kPa (138 bar) (2000 psi)
Pump	gear pump, driven by engine

BRAKES:

Type	mechanical, dry, internal expanding shoe
------	--

ELECTRICAL SYSTEM:

Type	12-volt, negative ground
Battery	one, 12-volt, BCI group 30H, 475 amps cold cranking, 160 minutes reserve capacity
Alternator	25-amp

TIRES AND TREADS:

See pages 06-6 and 06-7 in this section.

DIMENSIONS:

Wheelbase	1750 mm (69 in.)
Overall length (with 3-point hitch)	3100 mm (122 in.)
Height to muffler cover*	1970 mm (78 in.)
Height to top of ROLL-GARD canopy*	2180 mm (86 in.)
Overall width (minimum tread)	1650 mm (65 in.)
Turning radius	3100 mm (122 in.)

SHIPPING WEIGHT** 1350 kg (3000 lbs.)

*Tractor equipped with 13.6 - 28 rear tires and 6.00 - 16 front tires.

**Equipped for average field service, without fuel and ballast.

TRAVEL SPEEDS:*

Gear	km/h	mph
1st	1.37	.85
2nd	1.96	1.22
3rd	2.89	1.80
4th	4.28	2.66
5th	6.45	4.00
6th	9.20	5.72
7th	13.60	8.45
8th	20.10	12.50
1 R	1.96	1.22
2 R	9.20	5.72

*1050 Tractor equipped with 13.6 - 28 rear tires and engine at rated speed of 2400 rpm (575 PTO rpm).

Tune-Up

ITEM	SPECIFICATION
PTO Horsepower	
850.....	16.4 kW (22 hp)
950.....	20.1 kW (27 hp)
1050.....	24.6 kW (33 hp)
Compression	2916-4405 kPa (39.1-44.0 bar) (568 to 639 psi)
Thermostat opening temperature	71°C (160°F)
Radiator cap pressure release.....	98 kPa (1.0 bar) (14 psi)
Engine speeds	
850	
Slow idle	800 rpm
Fast idle	2700 rpm
Rated speed at full load	2600 rpm
950	
Slow idle	800 rpm
Fast idle	2600 rpm
Rated speed at full load	2400 rpm
1050	
Slow idle	800 rpm
Fast idle	2575 rpm
Rated speed at full load	2400 rpm

Lubrication

Engine crankcase oil capacity	
850.....	4.5 L (5 U.S. quarts)
950.....	6.4 L (7 U.S. quarts)
1050.....	6.4 L (7 U.S. quarts)
Transmission-hydraulic system capacity	
850 (-16000) and 950 (-20000) 2WD	18 L (19 U.S. quarts)
850 (16001-) and 950 (20001-) 2WD	20 L (21 U.S. quarts)
850 (16001-) and 950 (20001-) MFWD	22 L (23 U.S. quarts)
1050 (All)	27 L (28.5 U.S. quarts)
MFWD axle housing capacity	
850.....	6.5 L (6.9 U.S. quarts)
950 and 1050	8.5 L (8.9 U.S. quarts)
Service intervals	
Check engine oil level	Every 10 hours
Change engine oil	After first 50 hours then Every 100 hours
Replace engine oil filter	Every 200 hours
Clean crankcase breather tube	Every 600 hours
Check transmission-hydraulic oil level	Every 50 hours
Change transmission-hydraulic oil	Every 200 hours
Clean transmission-hydraulic oil screen	
850 and 950 without hydraulic filter	Every 200 hours
850, 950 and 1050 with hydraulic filter	After first 100 hours then Every 600 hours
Replace transmission-hydraulic oil screen	
850 and 950 without hydraulic filter	Every 600 hours
850, 950 and 1050 with hydraulic filter	Every 1200 hours
1050 (all)	Every 1200 hours

Tune-Up

ITEM	SPECIFICATION
PTO Horsepower	
850 and 900HC	16.4 kW (22 hp)
950	20.1 kW (27 hp)
1050	24.6 kW (33 hp)
Compression	3916-4405 kPa (39.1-44.0 bar) (568 to 639 psi)
Thermostat opening temperature	71°C (160°F)
Radiator cap pressure release	98 kPa (1.0 bar) (14 psi)
Engine speeds	
850 and 900HC	
Slow idle	800 rpm
Fast idle	2700 rpm
Rated speed at full load	2600 rpm
950	
Slow idle	800 rpm
Fast idle	2600 rpm
Rated speed at full load	2400 rpm
1050	
Slow idle	800 rpm
Fast idle	2575 rpm
Rated speed at full load	2400 rpm

Lubrication

Engine crankcase oil capacity	
850 and 900HC	4.5 L (5 U.S. quarts)
950	6.4 L (7 U.S. quarts)
1050	6.4 L (7 U.S. quarts)
Transmission-hydraulic system capacity	
850 (-16000) and 950 (-20000)	18 L (19 U.S. quarts)
850 (16001-), 950 (20001-), and 1050	27 L (28.5 U.S. quarts)
900HC	28 L (29.6 U.S. quarts)
MFWD axle housing capacity	
850	6.5 L (6.9 U.S. quarts)
950 and 1050	8.5 L (8.9 U.S. quarts)
Service intervals	
Check engine oil level	Every 10 hours
Change engine oil	After first 50 hours then Every 100 hours
Replace engine oil filter	After 50 hours then Every 200 hours
Clean crankcase breather tube	Every 500 hours
Check transmission-hydraulic oil level	Every 50 hours
Change transmission-hydraulic oil	After 100 hours then Every 200 hours
Clean transmission-hydraulic oil screen	
850, 900HC and 950 without hydraulic filter	Every 200 hours
850, 900HC, 950 and 1050 with hydraulic filter	After first 100 hours then Every 500 hours
Replace transmission-hydraulic oil screen	
850, 900HC and 950 without hydraulic filter	Every 500 hours
850, 900HC and 950 with hydraulic filter	Every 1000 hours
1050 (all)	Every 1000 hours

Front wheel drive 950 and 1050 Tractors only.

Lubrication—Continued

Replace transmission-hydraulic oil filter	
850, 900HC and 950 (if equipped)	After first 100 hours then Every 200 hours
1050 (all)	After first 100 hours then Every 200 hours
Check lubricant level in front axle housing*	Every 50 hours
Change lubricant in front axle housing*	After first 100 hours then Every 600 hours
Clean and repack front wheel bearings	Every 500 hours
Lubricate grease fittings	
Front axle pivot pin	Every 10 hours
All others	Every 50 hours

*Front-wheel drive 950 and 1050 tractors only

Separation

ITEM	SPECIFICATIONS
Fan belt deflection (at 89 N [20 lbs.] push)	10 to 15 mm (3/8 to 5/8 in.)
ROLL-GARD Cap Screws	
Top	100 N·m (75 ft-lbs)
Lower	245 N·m (180 ft-lbs)
Engine Fender-to-Axle housing	90 N·m (65 ft-lbs)
Fender-to-step	30 N·m (22 ft-lbs)
Step-to-transmission case	50 N·m (36 ft-lbs)
Axle housing-to-transmission case	50 N·m (36 ft-lbs)
Drag Link-to-Pitman Arm	50 N·m (36 ft-lbs)
Clutch housing-to-transmission case	
850 and 950 without front wheel drive	120 to 150 N·m (87 to 108 ft-lbs)
950 with front wheel drive and all 1050	170 to 200 N·m (123 to 145 ft-lbs)
Clutch housing-to-engine	90 N·m (65 ft-lbs)
Side frames-to-engine	90 N·m (65 ft-lbs)
Hydraulic lines-to-pump	8 N·m (5.8 ft-lbs)
Hood mounting bracket cap screws	50 N·m (36 ft-lbs)

SERVICE EQUIPMENT AND TOOLS

Name	Use
JDST-28 Belt Tension Tool	Check fan belt tension.
<i>Note: Order from your SERVICE-GARD™ Catalog.</i>	
Hand Tachometer	Check engine speed.
D-05104ST Radiator Tester	Pressure test cooling system and radiator caps.
AR62377 Dry Element Cleaning Gun	Clean air filter.
<i>Note: Order from Service Tools P.O. Box 314 Owatonna, MN 55060</i>	

Separation

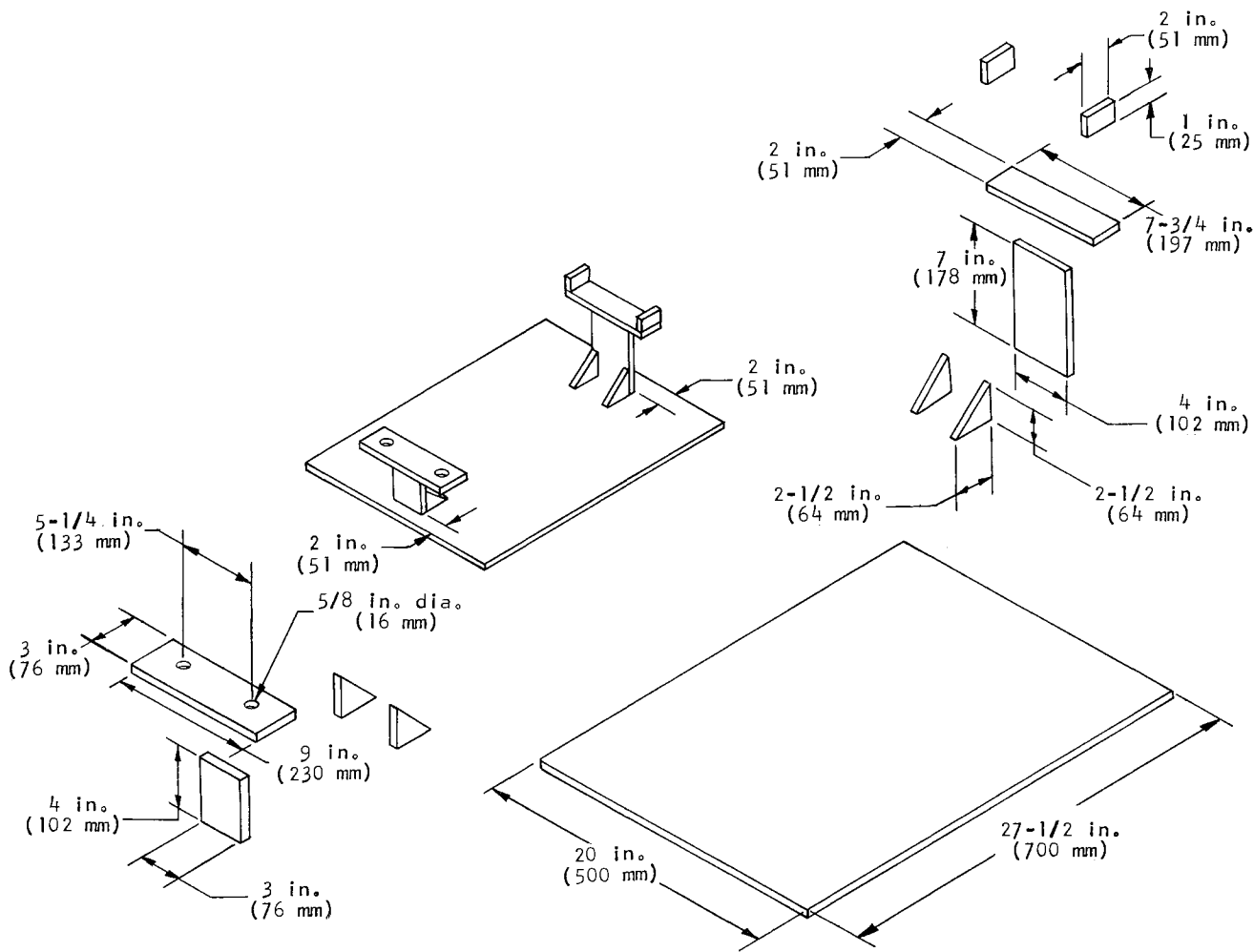

R 30803

Fig. 5-Transmission Stand

NOTE: Make from 5/16 in. steel and weld all joints.

Group 05

PREDELIVERY, DELIVERY, AND AFTER-SALE SERVICES 850 AND 950 TRACTORS

IMPORTANT: The 850 and 950 Tractors require set-up and assembly per instructions in shipping crates. Perform these operations prior to predelivery which follows.

The John Deere Delivery Receipt, when properly filled out and signed by the dealer and customer verifies that the predelivery and delivery services were satisfactorily performed. When delivering this machine give the customer his copy of the delivery receipt and the operator's manual. Explain their purpose to him.

Because of the shipping factors involved, plus extra finishing touches that are necessary to promote customer satisfaction, proper predelivery service is of prime importance to the dealer.

Instructions pointing out factory-recommended procedure for tractor setup and a tag pointing out factory-recommended procedure for predelivery are attached to the tractor.

After completing the factory-recommended dealer checks and services listed on the set up instructions and the predelivery tag, remove the tag and file it with the shop order for the job. The tag will certify that the tractor has received the proper predelivery service when that portion of the customer's John Deere Delivery Receipt is completed.

BEFORE STARTING TRACTOR

Before starting tractor, make a few quick checks to be sure it is in good operating condition. Check for any missing parts or damage.

Checking Engine Oil Level

Remove engine oil dipstick (Fig. 1) and wipe it off. Re-insert dipstick, but do not screw it down. Remove dipstick and check oil level. If necessary, add enough oil to bring oil level to top of cross hatch marks on dipstick. Use JOHN DEERE TORQUE-GARD SUPREME SAE 10W-20 or its equivalent.

NOTE: Tractor should be on a level surface when oil level is checked. If it is not, check only to make sure the crankcase is not dry. Recheck oil level later, when tractor is on level ground.

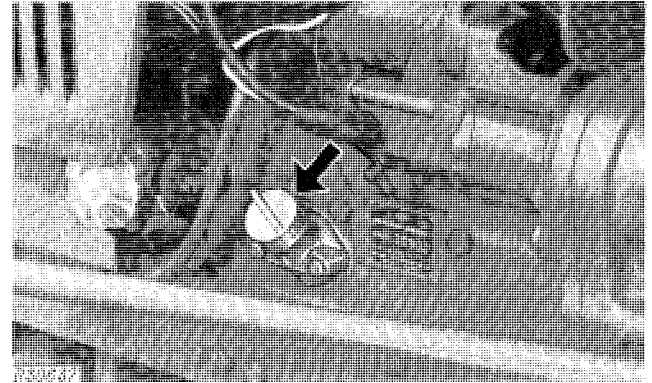
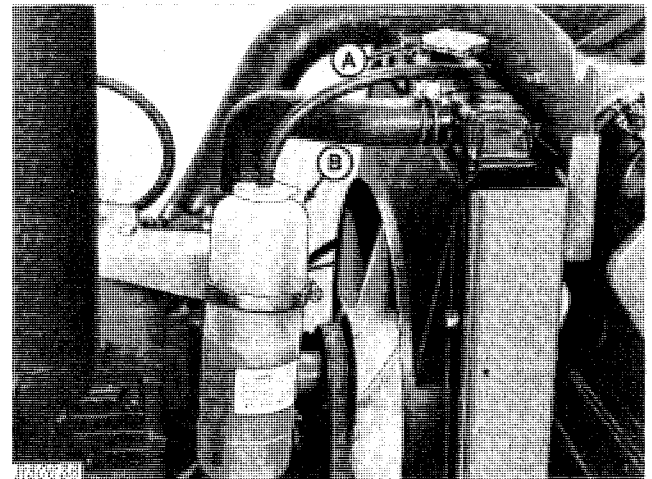

Fig. 1-Engine Oil Dipstick

Checking Coolant Level



A—Radiator Cap

B—Expansion Tank

Fig. 2-Coolant Level Checks

Remove the radiator cap (A, Fig. 2) and check the radiator coolant level. The radiator should be full of coolant. The expansion tank (B) should have coolant up to the full mark on the expansion tank.

Checking Transmission-Hydraulic System Oil Level

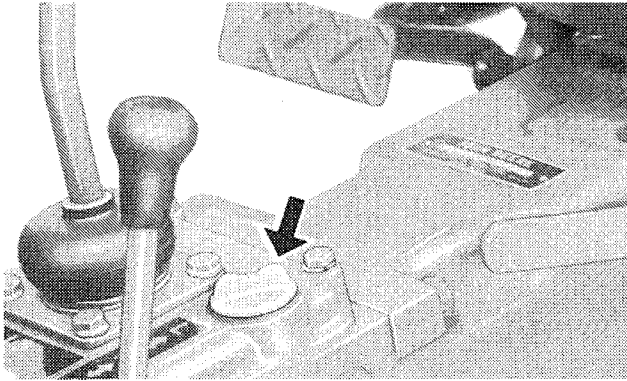

R30639

Fig. 3—Transmission-Hydraulic System Filler Cap

Remove transmission-hydraulic system filler cap (Fig. 3). Dipstick is attached to the filler cap. Re-insert dipstick, but do not screw it down. Remove dipstick and check oil level. If necessary, add enough oil to bring oil level to top of cross hatch marks on dipstick. Use JOHN DEERE HY-GARD Transmission and Hydraulic Oil or its equivalent.

NOTE: Tractor should be on level surface when oil level is checked. If it is not, check only to make sure the system is not dry. Recheck oil level later when tractor is on level ground.

Tire Pressure

Check the inflation pressure to be sure it is within the pressures listed in the following chart.

TIRE SIZE	PLY RATING	INFLATION PRESSURE					
		MINIMUM†			MAXIMUM		
		kPa	(bar)	(psi)	kPa	(bar)	(psi)
Front Tires							
5.00-15	4	170	(1.7)	(24)	280	(2.8)	(40)
5.50-16**	4	170	(1.7)	(24)	280	(2.8)	(40)
7-14*	4	80	(0.8)	(12)	176	(1.8)	(26)
7-16**	4	140	(1.4)	(20)	220	(2.2)	(32)
25/8.50-14*	4	80	(0.8)	(12)	155	(1.6)	(23)
27/8.50-15**	4	70	(0.7)	(10)	100	(1.0)	(14)
Rear Tires							
11.2-24	4	80	(0.8)	(12)	120	(1.2)	(18)
12.4-28**	4	80	(0.8)	(12)	110	(1.1)	(16)
13.6-16*	4	80	(0.8)	(12)	100	(1.0)	(14)
13.6-28**	6	80	(0.8)	(12)	150	(1.5)	(22)
44/18.0-20**	4	80	(0.8)	(12)	100	(1.0)	(15)
*850 Tractor Only							
**950 Tractor Only							

Checking Fuel Level

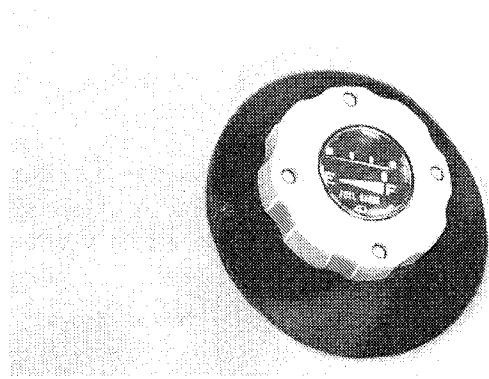

R30640

Fig. 4—Fuel Tank Filler Cap

Check fuel gauge to make sure tractor has enough fuel for driving around the lot. If not, add some. Do not run a diesel engine out of fuel.

STARTING TRACTOR

If the previous checks have been made and everything is all right, the tractor is ready to be started.

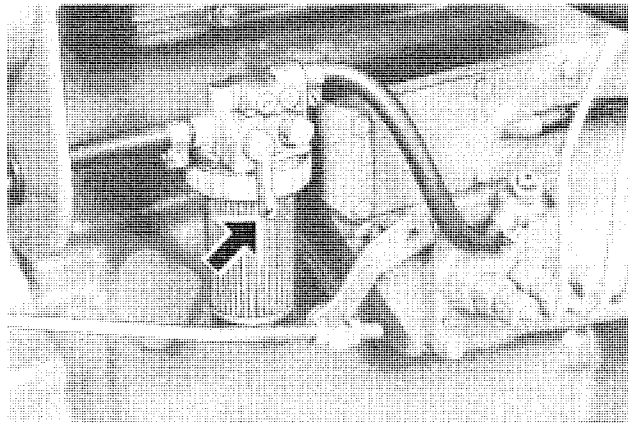

R30641

Fig. 5—Fuel Valve Handle

1. Open the fuel valve.
2. Put gear shift and PTO levers in neutral.
3. Push the throttle lever forward.

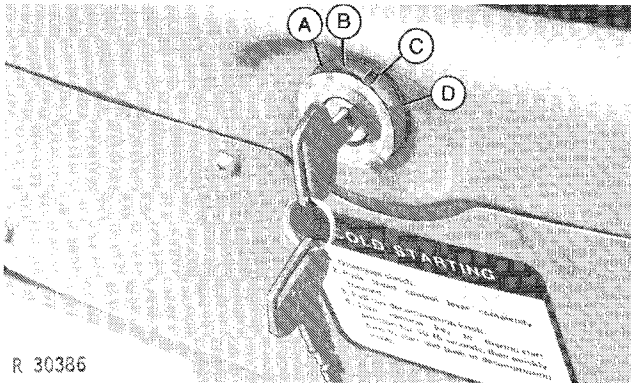

R 30386
A—Thermo-Start
B—Off

C—On
D—Start

Fig. 6-Ignition Switch Positions

4. Insert key in the switch and turn clockwise to first position (C, Fig. 6). The engine oil pressure and charge warning lamp should light up. If not, find out why and correct.

5. Depress clutch pedal.

NOTE: Engine will not start unless clutch pedal is fully depressed.

CAUTION: Depress clutch pedal from the operator's seat; NOT standing on the ground.

6. Turn the key fully clockwise (D, Fig. 6) to start engine. Run engine at approximately 1500 rpm.

IMPORTANT: Do not operate starter more than 20 seconds at a time to prevent overheating. Wait at least two minutes between attempts.

7. After engine starts, the oil pressure warning lights should go off. If not, stop engine and determine the cause.

8. Check brakes before moving tractor. Pedal travel should not exceed 25-35 mm (1.00 to 1.40 inches).

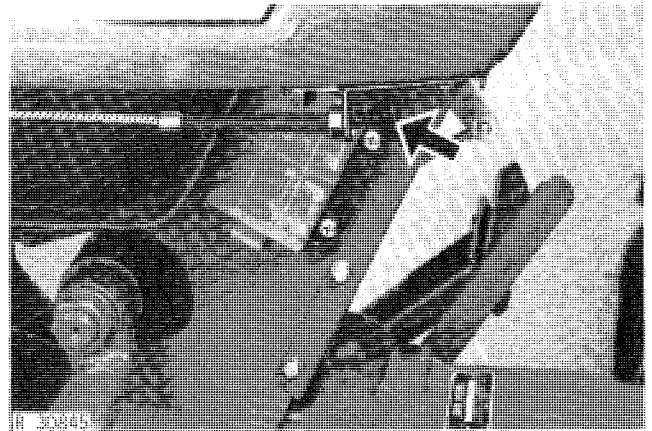

Fig. 7-Decompression Cable
(*Early Model Tractors Only)

NOTE: In cold weather, turn the key counterclockwise (A, Fig. 7) to activate the thermo-start. Hold for ten to fifteen seconds, pull the decompression cable (Fig. 7), then quickly turn to "start" position. Push in decompression cable as soon as engine starts turning.*

TRACTOR STORAGE

To prevent deterioration of tractor during storage, do the following to properly prepare it.

Short-Term (Under 30 Days)

1. Fill fuel tank to prevent condensation of moisture in tank.
2. Check engine oil level, transmission-hydraulic oil level, and coolant level. Add oil or coolant if necessary. During cold weather, be sure coolant contains sufficient anti-freeze.
3. Check electrolyte level in battery. If electrolyte does not cover plates, add distilled water. Make sure battery is fully charged.

*850 Tractor (-009000)
950 Tractor (-012000)

Short-Term (Under 30 Days)—Continued

Fig. 8-Clutch Fastened For Storage

4. Fasten clutch in a depressed position (Fig. 8) to prevent it from sticking.

5. Store tractor in a dry, protected place. If necessary to store tractor outside, cover it with a protective material. Protect tires from sunlight, heat and petroleum products.

Long Term (Over 30 Days)

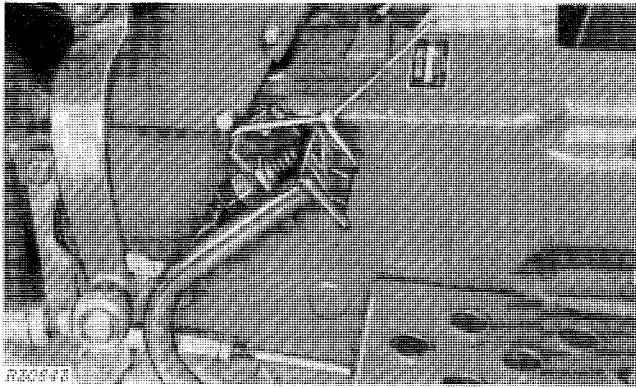
1. If tractor is to be stored longer than 30 days, use an AR41785 Engine Storage Kit. Follow the instructions in the kit, except do not change engine oil, replace filters or drain and flush cooling system on a new tractor.

2. Loosen fan belt.

3. Fasten clutch in a depressed position (Fig. 8) to prevent it from sticking.

4. Clean the tractor. Touch up any painted surfaces which are scratched or chipped.

5. Coat exposed metal surfaces with grease or corrosion preventative.

6. Store tractor in a dry protective place. If necessary to store tractor outside, cover it with a protective material. Protect tires from heat, sunlight and petroleum products.

7. When removing tractor from storage, remove protective cover and unseal all openings. Check engine oil level, transmission-hydraulic system oil level, coolant level and tire inflation pressure. Install battery, adjust belt tension and fill fuel tank.

PREDELIVERY SERVICE ELECTRICAL SYSTEM**Batteries**

1. Check battery terminals and battery cable ends. If they are corroded, clean and coat them with a mixture of petroleum jelly and baking soda.

2. Check electrolyte level in each battery cell. Add distilled water if necessary to bring level above cell plates.

3. If battery is not fully charged, charge it. Connect charger positive cable to the positive post on the battery and the ground cable to the negative post or the tractor frame.

Belt Tension

Fig. 9-Checking Fan Belt Tension

Check tension of fan belt and adjust if necessary. Fan belt should deflect 10 to 15 mm (3/8 to 5/8 inch) when a 89 N (20 lb.) force is applied.

Lighting

1. See that all lights work properly. With the light switch in "W" position, the warning lights should be on. In the "F" position the high beams and flood lamp should be on. In the "H₁" position the high beams, tail light and warning lamps should be on. In "H₂" position the low beams, tail light and warning lamps should be on.

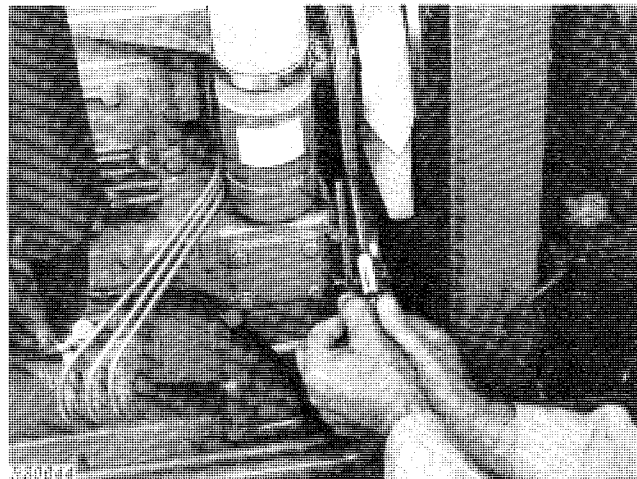
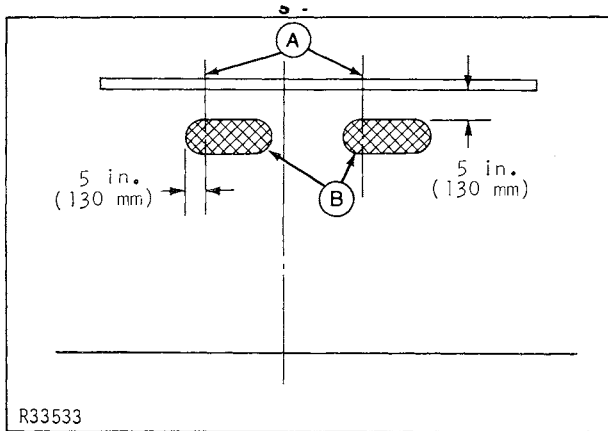

A—Points Directly in Front of Lamps
B—Small Zones of Bright Light

Fig. 10—Light Pattern at 25 ft. (8 m)

1. Park tractor on level ground, 8 m (25 feet) from a wall.
2. Measure height of lamps above ground, and place a strip of masking tape on wall at same height.
3. Sight across steering wheel and hood ornament to locate tractor centerline. Mark this spot, and measure out 130 mm (5 inches) in each direction. This locates a spot directly in front of each lamp.
4. Turn light switch to H2, which switches head lamps to low beam.
5. Locate small zone of bright light projected by each lamp. Top of bright zone should be 130 mm (5 inches) lower than lamp, and left edge of zone should be 130 mm (5 inches) to left of lamp. Cover other lamp if necessary.
6. Adjust lamp assemblies if necessary. Adjusting screws are behind bulbs. Open hood for access.

PREDELIVERY SERVICE COOLING SYSTEM

Coolant Level

Remove radiator cap (A, Fig. 11) to see if the radiator is full of coolant. The expansion tank (B, Fig. 11) should have coolant up to the full mark.

If coolant level is low, fill to proper level and determine where coolant was lost.

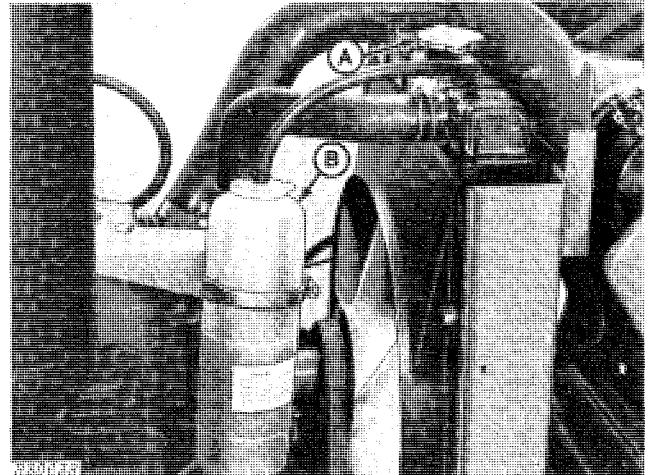

A—Radiator Cap

B—Expansion Tank

Fig. 11—Coolant Level Checks

Anti-Freeze Protection

Use a dependable, temperature-correcting hydrometer to check anti-freeze protection of coolant. If more is needed, use permanent type, ethylene glycol anti-freeze which contains a rust inhibitor but does not contain a stop-leak additive.

Leaks

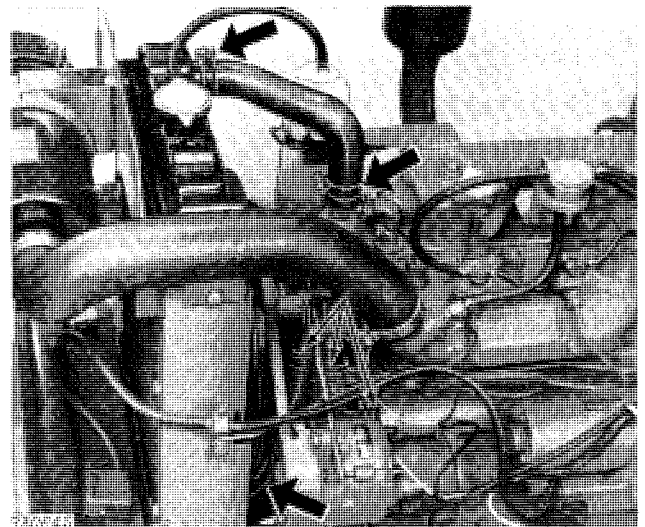
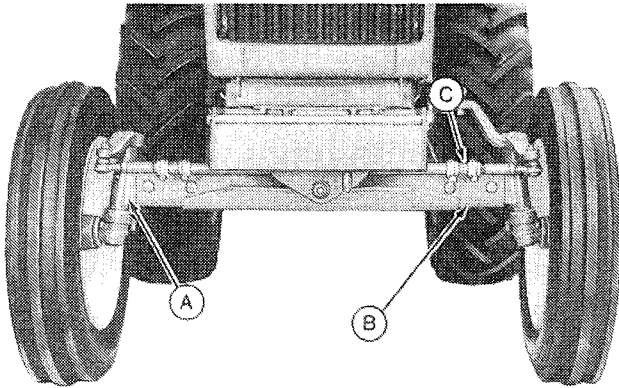

Fig. 12—Cooling System Connections

Check cooling system for any sign of leaks. Tighten clamps on radiator hoses.

TIRES, WHEELS AND WEIGHTS

Adjusting Front Tread Width



R30646

Fig. 13—Front Axle

Adjust front tread width to customer's needs.

1. Jack up front end of tractor.

NOTE: Do not place jack under engine oil pan.

2. Remove bolts from front axle (A, Fig. 13) and tie rods (C). Move the front axle knees (B) out to desired tread width.

3. Reinstall bolts. Tighten axle-to-knee bolts to 186 N·m (137 ft-lbs).

4. Adjust drag link so tractor will turn equally sharp in both directions. Chart below shows correct length of drag link for each tread width. Measure between centers of ball joints.

FRONT TREAD WIDTH DRAG LINK LENGTH

850 Tractor (2-Wheel Drive)

1115 mm (44 in.)	790 mm (31 in.)
1215 mm (48 in.)	793 mm (31-1/4 in.)
1315 mm (52 in.)	800 mm (31-1/2 in.)

850 Tractor (MFWD)

1060 mm (42 in.)	800 mm (31-1/2 in.)
------------------	---------------------

950 Tractor (2-Wheel Drive)

1160 mm (46 in.)	853 mm (33-1/2 in.)
1260 mm (50 in.)	859 mm (33-3/4 in.)
1360 mm (54 in.)	865 mm (34 in.)
1460 mm (58 in.)	875 mm (34-1/2 in.)

950 Tractor (MFWD)

1250 mm (49 in.)	815 mm (32 in.)
------------------	-----------------

5. Check toe-in each time front tread is changed.

Checking Toe-In

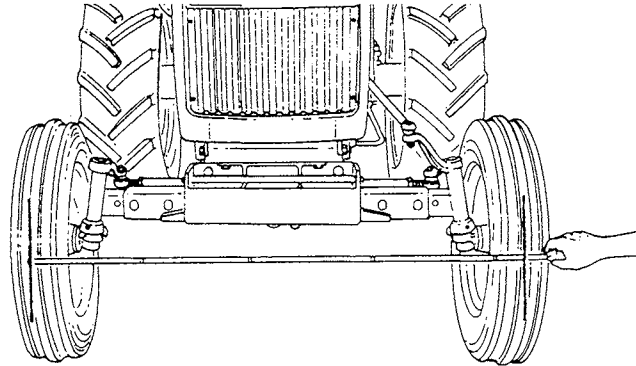

RW9654

Fig. 14—3 to 9 mm (1/8 to 3/8 in.) Toe-In

To check toe-in, steer the front wheels straight ahead and measure the distance from tire to tire, first in front and then at the rear. The front measurement should be 3 to 9 mm (1/8 to 3/8 inch) less than the rear.

If adjustment is needed, loosen lock nuts and turn tie rod tube until toe-in is correct. Tighten lock nuts.

Tie rods should be adjusted equal in length, so tractor will turn equally sharp in each direction.